



Pali Design, Inc.



1525 Hymus Boul.
Dorval, QC
H9P-1J5 Canada
Phone: 1-514-421-0309

customerservice@pali-design.com

www.pali-design.com

Assembly Instruction

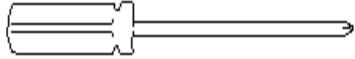
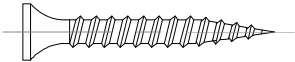
Wendy Universal Rails

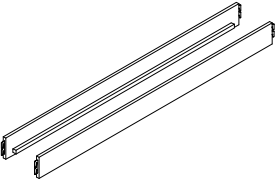
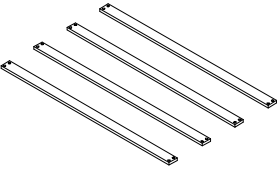
Hardware Parts List				Tools Needed for Assembly:	
A	Wood Screw	B	Allen Wrench		
	16x		1x		
					
					
Universal Rail Parts List				INSTRUCTION LEAFLET	
	2x		4x	<i>Important, keep for future reference. Read carefully.</i>	
	Universal Rail (C1 & C2)		Slat (D)		
				<i>Adult assembly is required.</i>	

Full-Size Bed **Step 1** **Transforming Crib into a Full-Size Bed**

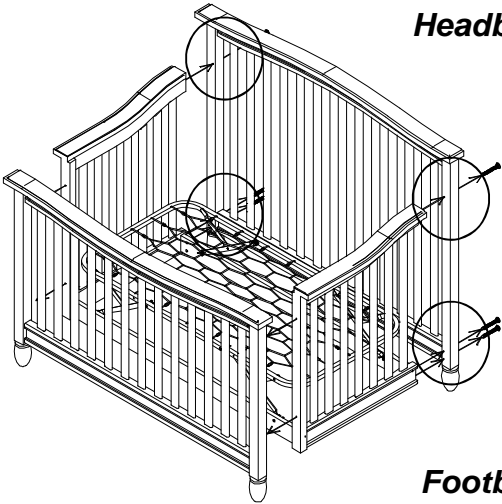

Headboard

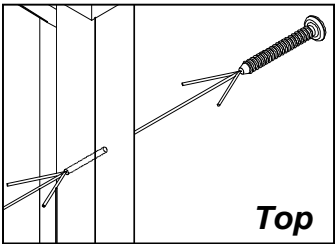

Top

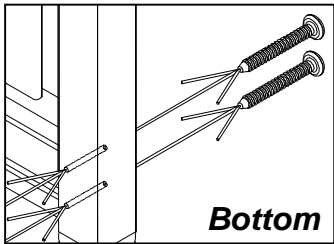

Bottom

Both End Panels

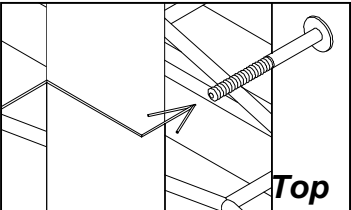

Top

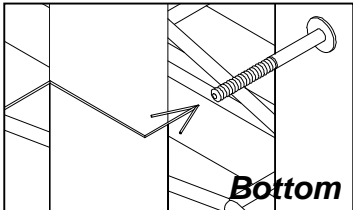

Bottom

Footboard

Full-Size Bed **Step 2** **Attach Bed Rails**

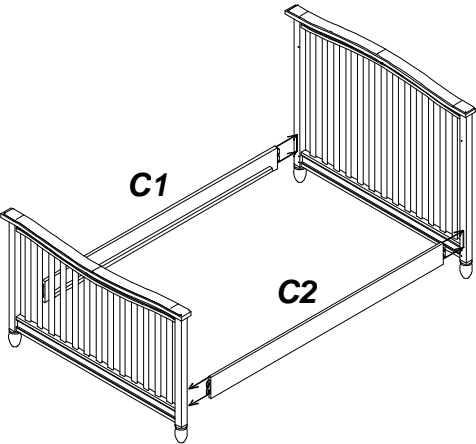

Headboard

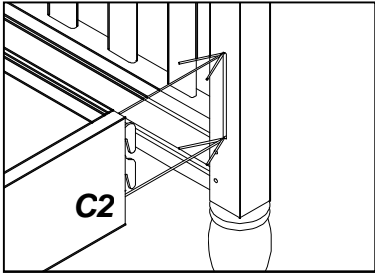

C2

Both Bed Rails

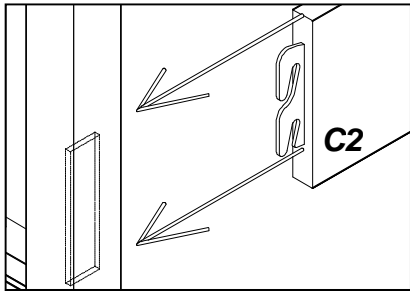

C2

Footboard

Attaching Slats

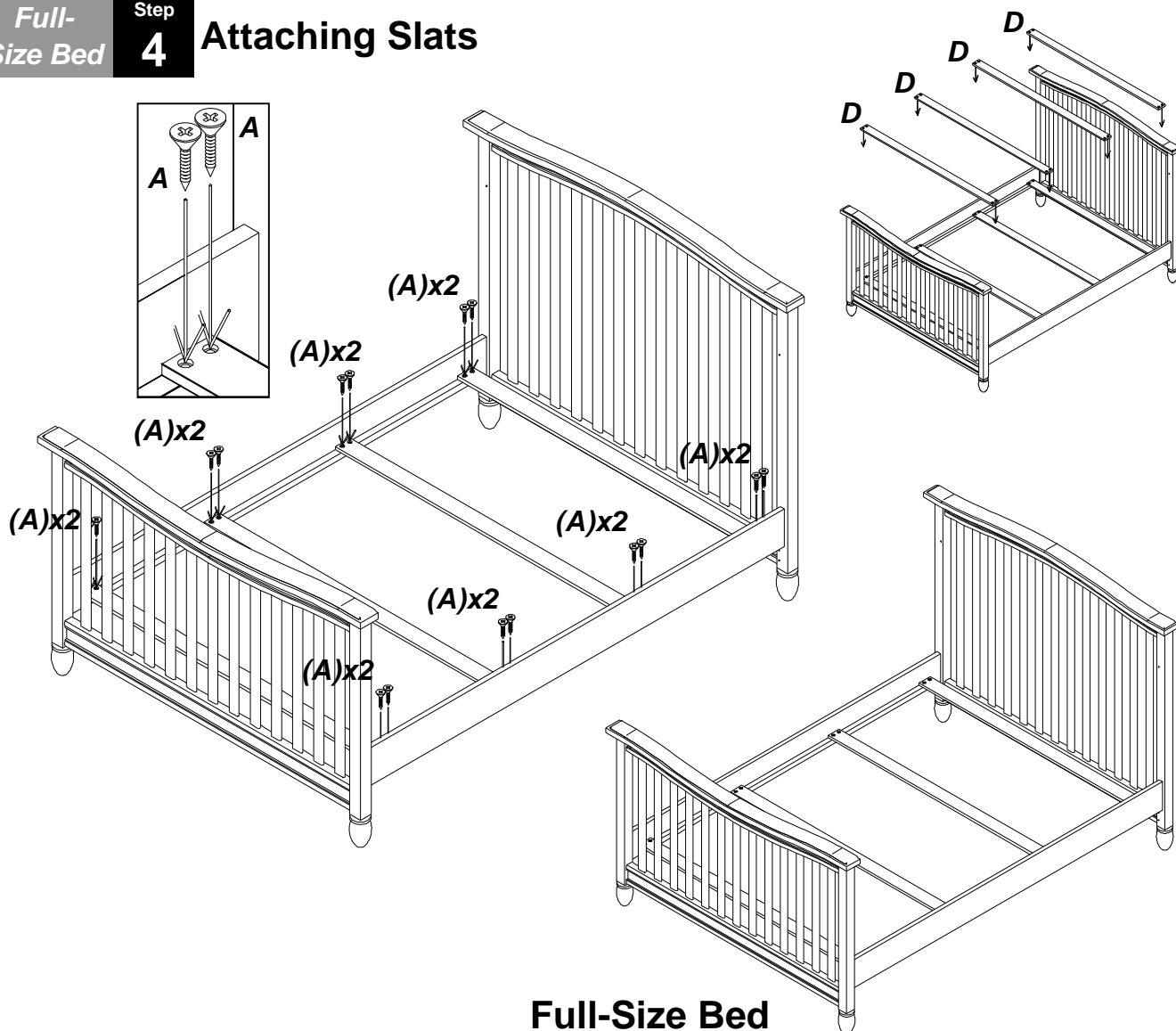

WARNING STATEMENTS

- Read all instructions before assembling crib. **Keep instructions for future use.**
- Failure to follow these warnings and the assembly instructions could result in serious injury or death.
- Never use plastic shipping bags or other plastic film as mattress covers because they can cause suffocation.
- Infants can suffocate in gaps between crib sides and a mattress that is too small.
- Infants can suffocate on soft bedding. Never add a pillow, comforter or padding.
- To reduce the risk of SIDS, pediatricians recommend healthy infants to be placed on their backs to sleep, unless otherwise advised by your physician.
- Strings can cause strangulation! Do not place items with a string around a child's neck, such as hood strings or pacifier cords. Do not suspend strings over a crib or attach strings to toys.
- To help prevent strangulation tighten all fasteners. A child can trap parts of the body or clothing on loose fasteners.

- DO NOT use a water mattress.
- If refinishing, use a non-toxic finish specified for children's products.
- DO NOT place crib near window where cords from blinds or drapes may strangle a child.
- When child is able to climb out or reaches the height of 35 in. (90 cm), the crib shall no longer be used.
- Check this product for damaged hardware, loose joints, missing parts or sharp edges before and after assembly and frequently during use. DO NOT use crib if any parts are missing, damaged or broken. Contact Pali for replacement parts and instructional literature if needed. DO NOT substitute parts.
- When child is able to pull to a standing position, set mattress to lowest position and remove bumper pads, large toys and other objects that could serve as steps for climbing out.
- CAUTION: ANY MATTRESS USED IN THIS CRIB MUST BE AT LEAST 27 1/4 IN. (69 CM) BY 51 5/8 IN. (131 CM) WITH A THICKNESS NOT EXCEEDING 6 IN. (15 CM)



TODDLER BED WARNING ENTRAPMENT / STRANGULATION HAZARD

- Failure to follow these warnings and the assembly instructions could result in serious injury or death.
- NEVER use bed with children under 15 months.
- NEVER place bed near windows where cords from blinds or drapes may strangle a child.
- The mattress intended for use on the bed shall be a full-size crib mattress having minimum dimensions of 51 5/8 in. (1310mm) in length, 27 1/4 in. (690mm) in width and 4 in. (100mm) in thickness.
- Do not place items with a string, cord, or ribbon around a child's neck, such as hood strings or pacifier cords.
- Do not suspend strings over a toddler bed for any reason.
- The minimum age of the intended user shall not be less than 15 months and the maximum weight shall not be greater than 50 lb (22.7 kg).



CARE AND MAINTENANCE

- When cleaning your crib, please use a non-toxic, non-abrasive cleaner. Mix a solution of water with a small amount of mild dishwashing liquid. Apply to crib surface with a soft, damp cloth lightly dampened in solution. After cleaning, dry completely with a soft, dry cloth.
- When storing crib use caution as extreme changes in temperature or humidity can compromise the crib making it extremely dangerous to your child.